

1 Introduction

The main focus of this experiment was to observe spectral lines emitted from samples of helium, hydrogen and neon gas to determine the Rydberg constant and the spacing of the lines on the diffraction grating. This was achieved by using a diffraction grating with an optical spectrometer to measure the deflection angles of the scattered light. By using a set of accepted values for the wavelengths of helium, it was possible to determine the spacing of the lines on the diffraction grating. The lines were found to be spaced $1679 \pm 1\text{nm}$ apart. Using this result, the Rydberg constant for Hydrogen was found to be $11070847 \pm 3.1 \times 10^4 \text{m}^{-1}$.

~~When an electric current is passed through a gas, electrons orbiting the gas atoms~~ will be excited into higher (unstable) energy levels from which they will decay, emitting radiation in the process. This phenomenon led J.J. Balmer to analyse the spectrum from a hydrogen discharge tube and empirically establish the following formula for the observed wavelengths:

$$\lambda = k \frac{n^2}{n^2 - 4} \quad (1)$$

With k empirically determined to be 364.6nm and n is an integer with the values 3 for the observed red line, 4 for the turquoise line, 5 for the violet line and 6 for the indigo line. This formula was later revised by J.R. Rydberg who changed it to

$$\frac{1}{\lambda} = R \left[\frac{1}{n_2^2} - \frac{1}{n_1^2} \right] \text{ for } n: 3,4,5\dots \quad (2)$$

where $n_2 = 2$ for the Balmer series (visible to the naked eye) and R , the Rydberg constant, was experimentally determined and the accepted value used in this experiment is $10967758 \pm 1\text{m}^{-1}$. Figure 1 shows the setup for the transmission grating spectrometer with the left and right dispersion angles indicated. Light

passing through the transmission grating will have maxima according to the formula:

$$m\lambda = d\sin(\theta). \quad (3)$$

With m being the respective order of the spectrum, so that the same line can reappear several times, at angles farther away from the central maximum (so $m = 0, 1, 2, \dots$) Here θ is the angle between the measured angle (right or left) and the "straight-through" angle measured in the beginning of the experiment. Using Eq. (3) ~~in reverse~~, with a known set of wavelengths, it is possible to determine d . This was done for the helium lines and thus the spacing between the lines of the transmission grating were determined.

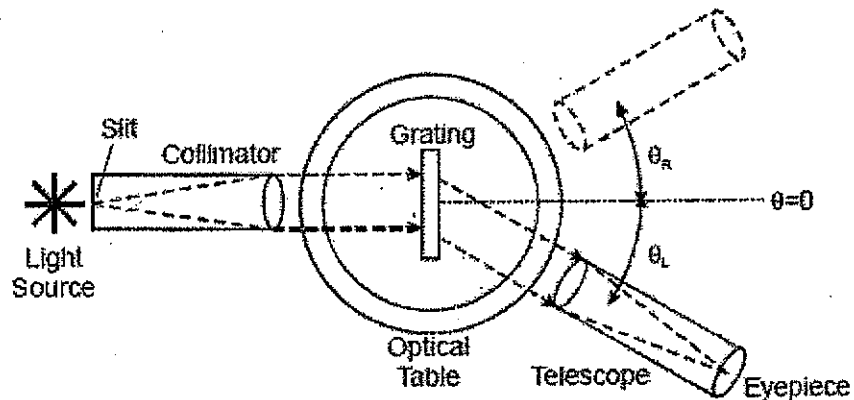

Figure 1: Sketch of the optical spectrometer.

2 Apparatus

- Lamp

- Precision Tool and Instrument Company (PTI) spectrometer at workstation 5
- Discharge tubes containing hydrogen, helium and neon
- Discharge tube holders
- High voltage discharge tube power supply
- Powerstat Variable autotransformer (Serial no. PN166B)
- Diffraction grating labelled 600 lines/mm

3 Procedure

Prior to measuring the angles of diffracted lines, the instrument has to be properly aligned to ensure accurate data. The procedure is described in detail in the manual¹ but a short description is given here.

1. First the telescope was focused on the light beam. This was done by aligning the light source, entrance slit, collimator, and telescope in a straight line. The eyepiece on the telescope was then adjusted until the crosshairs were seen in sharp focus. The crosshairs were rotated so that they formed an X and not a +.
2. The knob controlling the width of the entrance slit was adjusted and the collimator focused until the edges of the image were sharply defined and the image appeared vertical when looking through the telescope.
3. The telescope was moved until the image from the light was centered on the crosshairs. The telescope was then fixed in place.

¹Page 96 of the Physics 133 Reader 2011

4. Focusing the telescope so parallel rays will be in focus. This was achieved by placing a thin silvered mirror in the grating holder so the silvered surface was perpendicular to the telescope. By holding a piece of glass at roughly 45 degrees in front of the telescope, this acted as a half-silvered mirror. The light rays from a lamp could then be shone on the glass, reflected into the telescope, reflected off the mirror in the grating holder and back through the telescope causing 2 images of the crosshairs to be seen. By rotating the grating holder so that the two images of the crosshairs were superimposed and by adjusting the focus knob on the telescope, the telescope could be focused on parallel rays. This procedure is essential for the rest of the experiment ^{to ensure} as the rays diffracted from the diffraction grating will be parallel.

Once the spectrometer was aligned, the measurement of angles could begin. By applying a voltage of 85V from the variable autotransformer through each of the discharge tubes, spectral lines could be observed. Initially, the "straight-through" angle was measured for each sample. This was done by centering the telescope on the central maxima line and recording the angle. The telescope was then rotated until spectral lines were seen and their colour and angle were measured on both sides of the central maxima. These data are presented in part 4.

4 Data

^{→ in Table I}
Below are the ~~raw~~ data collected by measuring various angles and the colour of the lines observed for each of the three discharge tubes. The colours are approximate as many of the lines were too faint to tell the colour with absolute

certainty.

4.1 Helium

Narrative needed

Straight-through line: $177^{\circ}51'$

Color	Degrees (clockwise)	Degrees (counter-clockwise)	σ Degrees
Purple	$162^{\circ}33'$	$193^{\circ}11'$	03'
Blue	$161^{\circ}39'$	$194^{\circ}03'$	03'
Turquoise	$160^{\circ}57'$	$194^{\circ}42'$	03'
Teal	$160^{\circ}34'$	$195^{\circ}08'$	03'
Purpleish	$160^{\circ}25'$	$195^{\circ}11'$	03'
Yellow	$157^{\circ}32'$	$198^{\circ}09'$	03'
Red	$154^{\circ}32'$	$201^{\circ}5'$	03'
Blue (2nd)	$145^{\circ}54'$	$209^{\circ}41'$	03'

Table 1: Data collected for helium in degrees and minutes of arch. σ denotes the uncertainty. (2nd) indicates the line is observed in the second order of the spectrum.

4.2 Hydrogen

Straight-through line: $177^{\circ}55'$

State "what" for this, i.e. diffracted angles

Color	Degrees (clockwise)	Degrees (counter-clockwise)	σ Degrees
Indigo	$163^{\circ}57'$	$191^{\circ}56'$	03'
Purple	$163^{\circ}03'$	$192^{\circ}40'$	03'
Turquoise	$161^{\circ}10'$	$194^{\circ}31'$	03'
Red	$155^{\circ}04'$	$200^{\circ}42'$	03'
Purple (2nd)	$146^{\circ}58'$	$208^{\circ}48'$	03'

Table 2: Data collected for hydrogen in degrees and minutes of arch. σ denotes the uncertainty. (2nd) indicates the line is observed in the second order of the spectrum.

4.3 Neon

Straight-through line: $177^{\circ}59'$

Color	Degrees (clockwise)	Degrees (counter-clockwise)	σ Degrees
Yellow	$157^{\circ}35'$	$198^{\circ}02'$	03'
Red	$155^{\circ}39'$	$200^{\circ}04'$	03'
Orange	$156^{\circ}31'$	$199^{\circ}10'$	03'
Blue	$159^{\circ}11'$	$196^{\circ}29'$	03'
Green(1)	$157^{\circ}56'$	$197^{\circ}46'$	03'
Green(2)	$159^{\circ}12'$	$196^{\circ}29'$	03'

Table 3: Data collected for helium in degrees and minutes of arch. σ denotes the uncertainty. Note Green(1) and Green(2) indicate 2 different shades of green, not the second order spectrum.

When using a He-Ne Laser in conjunction with the discharge tube, it was observed that the Laser spectral line nearly coincided with a red line emitted from the discharge tube at $155^{\circ}49'$.

↑ either it did or it didn't

5 Data Analysis and Results

5.1 Determining the diffraction grating spacing, d .

By using a known set of values for the wavelengths of helium, it is possible to calculate the value d , the spacing of the lines in the diffraction grating by the relation:

$$d = \frac{\lambda_{REF}}{\sin(\theta)} \quad (4)$$

where $\theta = \frac{1}{2}(\theta_1 + \theta_2)$ and $\theta_1 = (\alpha_1 - \alpha_0)$ where α_0 is the straight-through line and α_1 is the measured angle clockwise (similarly α_2 and θ_2 are for the counterclockwise measured angles).

The uncertainty in d can be calculated by the following equation:

$$\sigma_d = \frac{\lambda_{REF} \cos(\theta)}{\sin^2(\theta)} \sigma_\theta. \quad (5)$$

Where $\sigma_\theta^2 = \frac{1}{2}(03')$ since it was judged that the angles could only be measured to within ± 3 minutes of arc. Before using eq. (4) the recorded spectral lines have to be identified so they may be matched to the correct reference lines. This was done by first assuming the labelled value of 600 lines/mm is correct (corresponding to 1667 nm per line). Then, once the lines are matched up, we can use eq.(4) to deduce a better value for d by averaging over all the measured angles. The calculated data are presented in Table 4.

$\theta(\text{deg})$	$\theta(\text{rad})$	$\lambda(\text{nm})$	$\lambda_{REF}(\text{nm})$	$\Delta\lambda(\text{nm})$	$d(\text{nm})$	$\sigma d(\text{nm})$
15.32	0.27	444.67	438.79	5.88	1661	4
16.20	0.28	469.7	471.31	-1.61	1689	4
16.88	0.29	488.71	492.19	-3.48	1696	3
17.28	0.30	500.09	501.57	-4.68	1689	3
17.38	0.30	502.9	504.77	1.33	1690	3
20.31	0.35	584.37	587.56	-3.19	1693	3
23.28	0.41	665.25	667.81	-2.56	1690	2
31.89	0.56	444.71	438.79	5.92	1661	2

Table 4: Calculated data to determine the value of d , using known values of the wavelengths emitted.

The spacing between the lines and the associated uncertainty can then be calculated by the following equations:

$$\bar{d} = \frac{\sum d_i / \sigma_i^2}{\sum 1 / \sigma_i^2}; \quad \sigma_{\bar{d}} = \left[\sum \frac{1}{\sigma_i^2} \right]^{-\frac{1}{2}}. \quad (6)$$

The calculated value for d is 1684 ± 1 nm.

5.2 Determining the Rydberg constant for hydrogen

The Rydberg constant for hydrogen is found by using the observed data from hydrogen (Table 2) and by using the following equation:

$$R_H = \frac{1}{\lambda} \left[\frac{1}{n_2^2} - \frac{1}{n_1^2} \right]^{-1} \quad (7)$$

Since there is an error that is carried forward from the determination of d , an intermediate quantity, Q , can be defined as:

$$Q = \sin(\theta) \left[\frac{1}{n_2^2} - \frac{1}{n_1^2} \right] \quad (8)$$

Since $\frac{1}{\lambda} = m \sin(\theta)$ was defined previously. Using equation (8), each Q_i can be determined independently and n_2 and n_1 are such that all Q_i determine the same value. The error on Q is then found to be:

$$\sigma_{Q_i} = \sigma_\theta \cos(\theta_i) \left[\frac{1}{n_2^2} - \frac{1}{n_1^2} \right] \quad (9)$$

Once all Q_i 's are found, the average value can be determined (\bar{Q}). The Rydberg constant may then be expressed as $R_H = (\bar{d}\bar{Q})^{-1}$ with an associated error of $\sigma_{R_H} = R_H \left[\left(\frac{\sigma_{\bar{d}}}{\bar{d}}\right)^2 + \left(\frac{\sigma_{\bar{Q}}}{\bar{Q}}\right)^2 \right]^{\frac{1}{2}}$. The calculated data are presented in Table 5.

Colour	θ (deg)	θ (rad)	Q	σ_Q	n_2	n_1
Indigo	13.99	0.24	0.05	0.02×10^{-2}	2	6
Purple	14.81	0.26	0.05	0.02×10^{-2}	2	5
Turquoise	16.68	0.29	0.05	0.01×10^{-2}	2	4
Red	22.82	0.40	0.05	0.01×10^{-2}	2	3
Purple (2nd)	30.92	0.54	0.05	0.02×10^{-2}	2	5

Table 5: Calculated data for determining the Rydberg constant for hydrogen.

The Rydberg constant for hydrogen was determined to be $11070847 \pm 3.1 \times 10^4 \text{m}^{-1}$. The experimentally accepted value is $10967758 \pm 1 \text{m}^{-1}$. This means that the value determined in this experiment is off by 0.9% which is deemed acceptable.

*not relevant
the only thing that
matters is size of
error estimate*

6 Conclusion

Using an optical spectrometer to measure the angular dispersion of spectral lines from a helium, hydrogen and neon source, the Rydberg constant was determined using a transmission grating and a known set of wavelengths for helium was used to determine the grating spacing. By determining the angles for 8 lines from the helium source, the transmission grating was found to have a spacing of 1684 ± 1 nm/line. 4 Balmer lines up to 2nd order were found for hydrogen and using these, the Rydberg constant was found to be $11070847 \pm 3.1 \times 10^4 \text{m}^{-1}$ which is 0.9% from the experimentally accepted value. The values obtained in this experiment are compared with the value for the Rydberg constant given in the experiment manual: $10967758 \pm 1 \text{m}^{-1}$ and the λ_{REF} for helium were also found in the manual.

Handwritten notes in the bottom left corner, likely bleed-through from the reverse side of the page. The text is mirrored and difficult to decipher but appears to contain technical details related to the experiment.

References

- Physics 133 Reader written for the University of California, Santa Cruz
- “A Practical Guide to Data Analysis for Physical Science Students” by Louis Lyons
- Experimental Physics 2 Laboratory Manual Version 1.6 (Oct 2009) Malcolm McMahon (The University of Edinburgh)